

C200 Preamp/Controller



C200

The lightning flash with arrowhead, within an equilateral triangle, is intended to alert the user to the presence of uninsulated "dangerous voltage" within the product's enclosure that may be of sufficient magnitude to constitute a risk of electric shock to persons.



AVIS RISQUE DE CHOC ELECTRIQUE - NE PAS OUVRIR.

The exclamation point within an equilateral triangle is intended to alert the user to the presence of important operating and maintenance (servicing) instructions in the literature accompanying the appliance.

WARNING - TO REDUCE RISK OF FIRE OR ELECTRICAL SHOCK, DO NOT EXPOSE THIS EQUIPMENT TO RAIN OR MOISTURE.

NO USER-SERVICEABLE PARTS INSIDE. REFER SERVICING TO QUALIFIED PERSONNEL.

To prevent the risk of electric shock, do not remove cover or back. No user serviceable parts inside.

IMPORTANT SAFETY INSTRUCTIONS!

PLEASE READ THEM BEFORE OPERATING THIS EQUIPMENT.

General:

1. Read these instructions.
2. Keep these instructions.
3. Heed all warnings.
4. Follow all instructions.
5. **Warning: To reduce risk of fire or electrical shock, do not expose this equipment to rain or moisture. This unit is capable of producing high sound pressure levels. Continued exposure to high sound pressure levels can cause permanent hearing impairment or loss. User caution is advised and ear protection is recommended when playing at high volumes.**
6. **Caution: to prevent electrical shock do not use this (polarized) plug with an extension cord, receptacle or other outlet unless the blades can be fully inserted to prevent blade exposure. Attention: pour prevenir les chocs electriques pas utiliser cette fiche polarisee avec un prolongateur, une prise de courant ou un autre sortie de courant, sauf si les lames peuvent etre inserees afond ans en laisser aucune partie a decouvert.**
7. Unplug this equipment during lightning storms or when unused for long periods of time.
8. Only use attachments/accessories specified by the manufacturer.

Installation:

9. The equipment shall be installed near the AC Socket Outlet and the disconnect device shall be easily accessible.
10. Do not block any ventilation openings. Install in accordance with the manufacturer's instructions.
11. Do not install near any heat sources such as radiators, heat registers, stoves, or other equipment (including amplifiers) that produce heat.
12. Do not use this equipment near water.
13. Do not expose this equipment to dripping or splashing and ensure that no objects filled with liquids, such as vases, are placed on the equipment.
14. Use only with the cart, stand, tripod, bracket, or table specified by the manufacturer, or sold with the equipment. When a cart is used, use caution when moving the cart/equipment combination to avoid injury from tip-over.



Connection:

15. Connect this equipment only to the type of AC power source as marked on the unit.
16. Protect the power cord from being walked on or pinched particularly at plugs, convenience receptacles, and the point where they exit from the equipment.
17. Do not defeat the safety purpose of the polarized or grounding-type plug.

A polarized plug has two blades with one wider than the other. A grounding type plug has two blades and a third grounding prong. The wide blade or the third prong are provided for your safety. If the provided plug does not fit into your outlet, consult an electrician for replacement of the obsolete outlet.

18. Do not overload wall outlets, extension cords or integral convenience receptacles as this can result in a risk of fire or electric shock.
19. To completely disconnect this equipment from the AC Mains, disconnect the power supply cord plug from the AC receptacle.

Care of Equipment:

20. Clean only with a dry cloth.
21. Do not permit objects or liquids of any kind to be pushed, spilled and/or fall into the equipment through enclosure openings.
22. Unplug the power cord from the AC power outlet when left unused for a long period of time.

Repair of Equipment:

23. Refer all servicing to qualified service personnel. Servicing is required when the equipment has been damaged in any way, such as power-supply cord or plug is damaged, liquid has been spilled or objects have fallen into the equipment, the equipment has been exposed to rain or moisture, does not operate normally, or has been dropped.
24. Do not attempt to service beyond that described in the operating instructions. All other service should be referred to qualified service personnel.
25. When replacement parts are required, be sure the service technician has used replacement parts specified by McIntosh or have the same characteristics as the original part. Unauthorized substitutions may result in fire, electric shock, or other hazards.
26. Upon completion of any service or repairs to this product, ask the service technician to perform safety checks to determine that the product is in proper operating condition.

Thank You

Your decision to own this McIntosh C200 Preamplifier/Controller ranks you at the very top among discriminating music listeners. You now have "The Best." The McIntosh dedication to "Quality," is assurance that you will receive many years of musical enjoyment from this unit.

Please take a short time to read the information in this manual. We want you to be as familiar as possible with all the features and functions of your new McIntosh.

Please Take A Moment

The serial number, purchase date and McIntosh dealer name are important to you for possible insurance claim or future service. The spaces below have been provided for you to record that information:

Serial Number: _____

Purchase Date: _____

Dealer Name: _____

Technical Assistance

If at any time you have questions about your McIntosh product, contact your McIntosh dealer who is familiar with your McIntosh equipment and any other brands that may be part of your system. If you or your dealer wish additional help concerning a suspected problem, you can receive technical assistance for all McIntosh products at:

McIntosh Laboratory, Inc.
2 Chambers Street
Binghamton, New York 13903
Phone: 607-723-1545
Fax: 607-723-3636

Customer Service

If it is determined that your McIntosh product is in need of repair, you can return it to your dealer. You can also return it to the McIntosh Laboratory Service Department. For assistance on factory repair return procedure, contact the McIntosh Service Department at:

McIntosh Laboratory, Inc.
2 Chambers Street
Binghamton, New York 13903
Phone: 607-723-3515
Fax: 607-723-1917

Table of Contents

Safety Instructions	2
Thank You and Please Take a Moment.....	3
Technical Assistance and Customer Service	3
Table of Contents and General Notes	4
Introduction	5
Performance Features	5
Dimensions	6
Installation	8
Connections	
C200C Rear Panel Connections	10
C200P Rear Panel Switches and Connections	11
How to Connect the C200	12
How to Connect the C200 with Passthru Mode	14
Front Panel Features	
C200P Front Panel Display and Connection	16
C200C Front Panel Controls, Displays, Push-Buttons, and Switches	17
Setup	
How to Operate the Setup Mode	18
Default Settings	18
Display Brightness	18
Text Display Options	18
Input Trim Level	19
Input Selection	19
Volume Control Rate-of-Change	20
Balance Control Rate-of-Change	20
Passthru Mode	20
Remote Control Selection	21
Firmware Version	21
Operation	
How to Operate the C200	22
Remote Control Push-buttons	24
How to operate the Remote Control	25
Additional Information	
Specifications	26
Packing Instruction	27

General Notes

1. The C200 consist of two separate chassis. The C200 Controller Chassis will be referred to as the C200C throughout this Owner's Manual. In a similar manner, the C200 Preamplifier Chassis will be referred to as the C200P throughout this Owner's Manual.
2. For additional information on Audio Connections, refer to the Owner's Manual(s) for the component(s).
3. Connecting Cables and Connectors are available from the McIntosh Parts Department:
Data and Power Control Cable Part No. 170-202
 Six foot, shielded 2 conductor, with 1/8 inch stereo mini phone plug on each end.
Controller to Preamplifier Cable Part No. 170-631
 Six foot, DB25, shielded, straight through, 25 conductor male-to-female cable.
4. The Main AC Power going to the C200C and any other McIntosh Component(s) should not be applied until all the system components are connected together. When the C200C and other McIntosh Components are in their Standby Power Off Mode, the Microprocessor's Circuitry inside each component is active and communication is occurring between them. Failure to do so could result in malfunctioning of some or all of the system's normal operations.
5. Up to four sensors can be wired in parallel for Remote Control of the C200 from other rooms.
6. Balanced and Unbalanced Inputs and Outputs can be mixed. For example, you may connect signal sources to Unbalanced Inputs and send signals from the Balanced Outputs. You can also use Balanced and Unbalanced outputs simultaneously, connected to different power amplifiers.
7. A McIntosh Power Controller may be added to the C200 to provide AC Power Switching to components that do not have Power Control Connections. See your McIntosh Dealer for additional information.
8. Sound Intensity is measured in units called Decibels and "dB" is the abbreviation.
9. Pin configuration for the XLR Balanced Input and Output Connectors on the C200P. Refer to the diagram for connection:

- PIN 1: Shield or ground
- PIN 2: + input
- PIN 3: - input

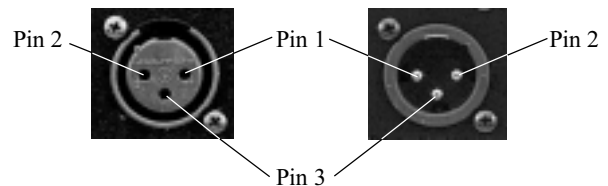

Introduction

The McIntosh C200 Preamplifier/Controller is without question the finest audio preamplifier ever created. No design compromises were allowed in the quest for a preamplifier with absolute accuracy, total sonic purity and virtual elimination of distortion and audible noise. For those who have been searching for their “Last Preamplifier”, your search is over.

Performance Features

- **Dual Chassis**

Dual Chassis design completely separates all power supply, microprocessor and control circuits from the pure audio circuits for total noise isolation.

- **Balanced and Unbalanced Inputs/Outputs**

Three balanced high level inputs, three balanced main outputs and one balanced tape output are provided. Eight unbalanced inputs, three unbalanced outputs as well as listen and record processor loops are included.

- **Precision Tracking Volume Control**

Volume levels are controlled by a new Multi-Stage Precision Digitally Controlled Attenuator System with a tracking accuracy of 0.1dB. Levels change in 213 individual 0.5dB steps.

- **Variable Rate Volume and Balance Control Selection**

The Volume and Balance Control Circuitry allows for user selected rate-of-change from loud to quiet and from left to right level adjustments.

- **Alphanumeric Fluorescent Display**

The Multifunction Front Panel Display indicates the Listen and Record Source Selection, Volume and Balance Levels. Setup Mode Selections and Adjustments are also displayed. The display intensity is fully adjustable.

- **Precision Volume Display**

The front panel digital Volume Display indicates the preamplifier gain in dB or percentage of available volume.

- **Input Level Trim Adjustment**

All eleven Inputs on the C200 can be matched in level, so that there are no abrupt changes in volume levels between the different inputs.

- **Precision Parts**

Only the finest precision 1% tolerance resistors and polypropylene capacitors are used throughout.

- **Ultra Low Distortion**

Distortion levels of all types are less than 0.002%. Music is amplified with total transparency and accuracy.

- **Moving Coil and Moving Magnet Phono Input**

There is a special, separately shielded precision Phono Preamplifier for low output Moving Coil Phono Cartridges, that utilizes two step-up transformers which contain coils wound with silver wire and double mu metal shielding. There is also a Precision Phono Preamplifier for Moving Magnet Cartridges.

- **Multichannel Passthru Mode**

The Automatic Passthru Mode allows the C200 to become part of a Multichannel Sound System for DVD-Audio and Home Theater. The Left and Right Channels of the C200 become the two front channels, simply by turning on the Multichannel Processor.

- **Full featured Remote Control**

The C200 includes a Remote Control that allows remote operation of the front panel controls and push-buttons.

- **Optional External Sensor Input**

There are provisions for connecting external sensors, which allow for enjoying your McIntosh System from other room(s) in your home via the remote control.

- **Power Control Output**

A Power Control connection for convenient turn-on of McIntosh power amplifiers and accessories is included.

Dimensions

The following dimensions can assist in determining the best location for the C200C Controller and C200P Preamplifier. There is additional information on the following pages pertaining to installing the C200C and C200P into cabinets.

Front View of the C200C

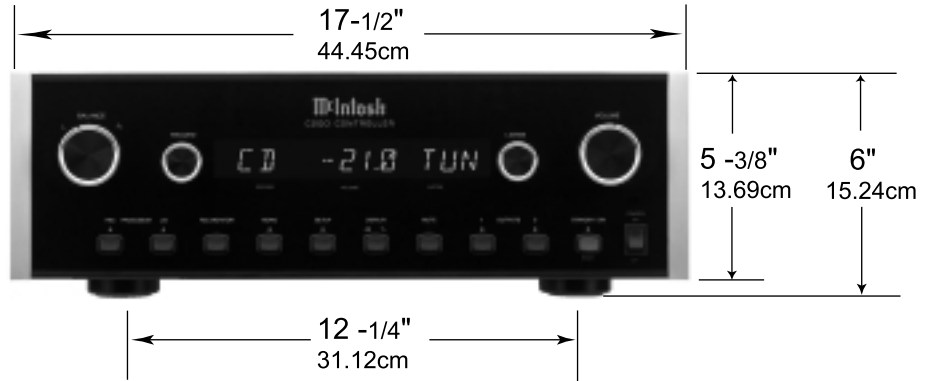

Rear View of the C200C

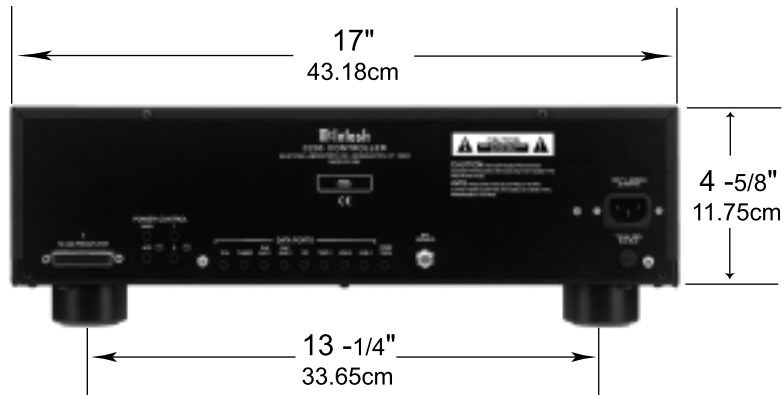

Side View of the C200C

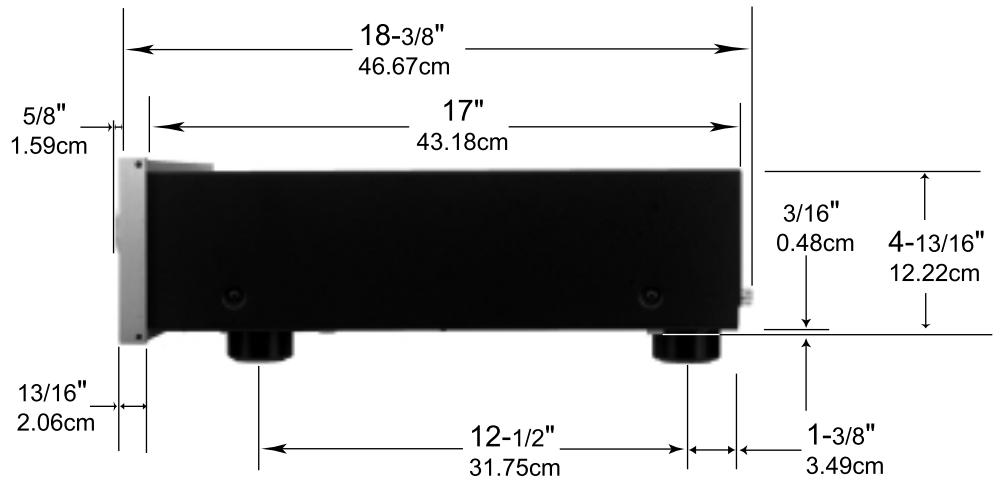

Front View of the C200P

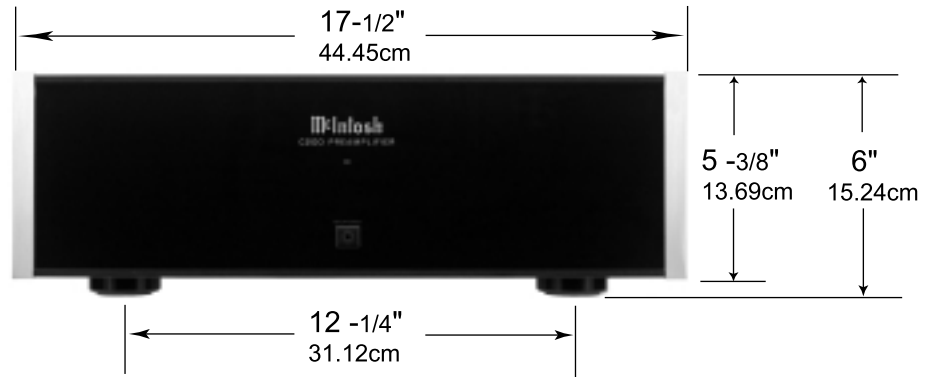

Rear View of the C200P

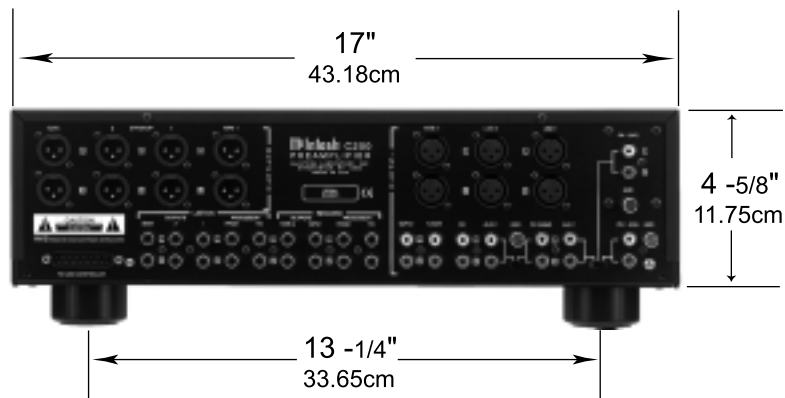

Side View of the C200P

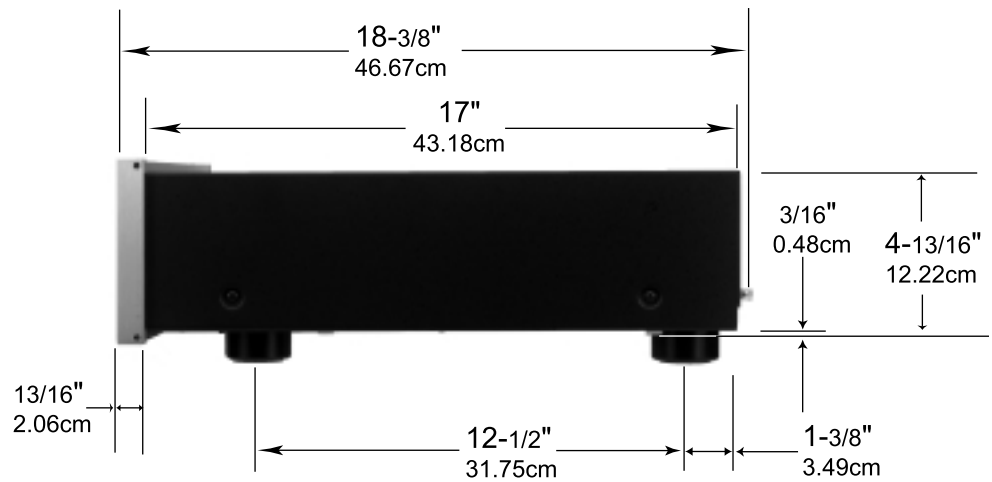

powered amplifier. If all the components are installed in a single cabinet, a quiet running ventilation fan can be a definite asset in maintaining all the system components at the coolest possible operating temperature.

A custom cabinet installation should provide the following minimum spacing dimensions for cool operation. Allow at least 2 inches (5.08cm) above the top, 2 inches (5.08cm)

below the bottom and 1 inch (2.54cm) on each side of the Controller and Preamplifier, so that airflow is not obstructed. Allow 20 inches (50.8cm) depth behind the front panel. Allow 1 inch (2.54cm) in front of the mounting panel for knob clearance. Be sure to cut out a ventilation hole in the mounting shelf according to the dimensions in the drawing.

**C200P Front Panel
Custom Cabinet Cutout**

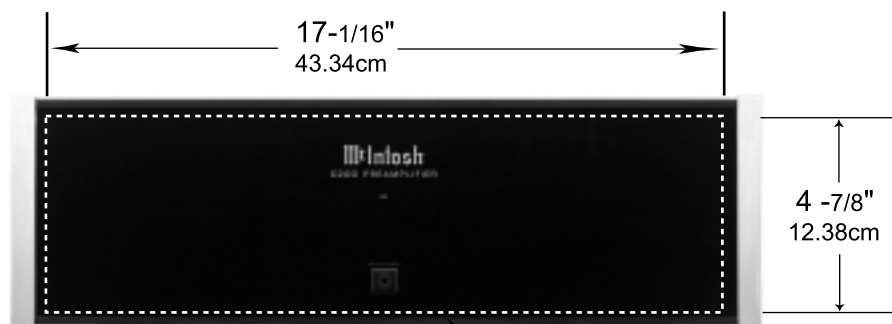

Cutout Opening for Custom Mounting

**C200P Side View
in Custom Cabinet**

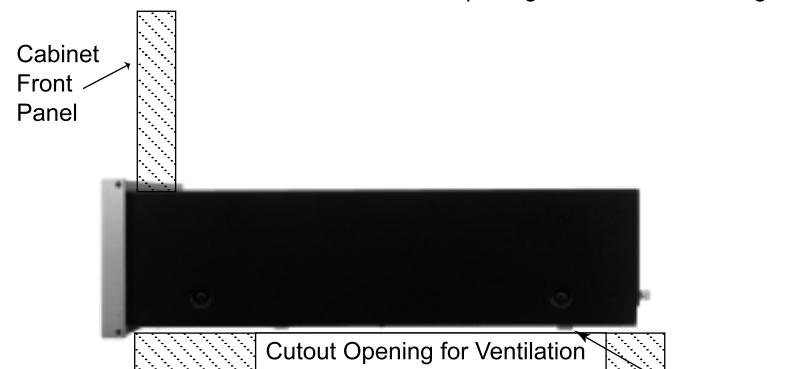

**C200P Bottom View
in Custom Cabinet**

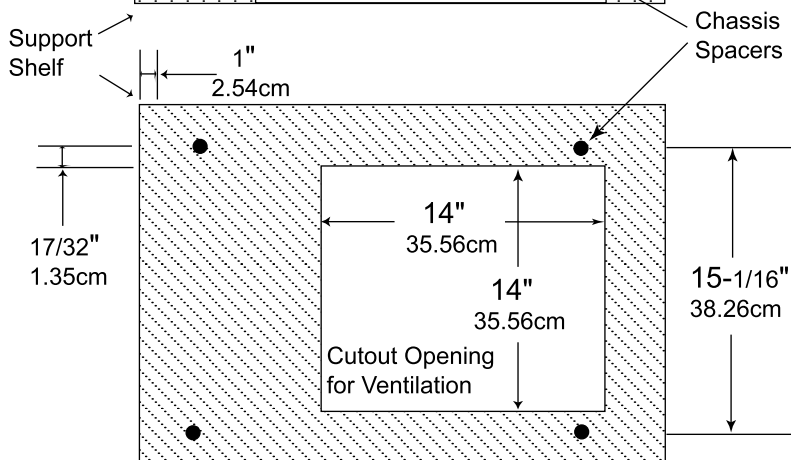

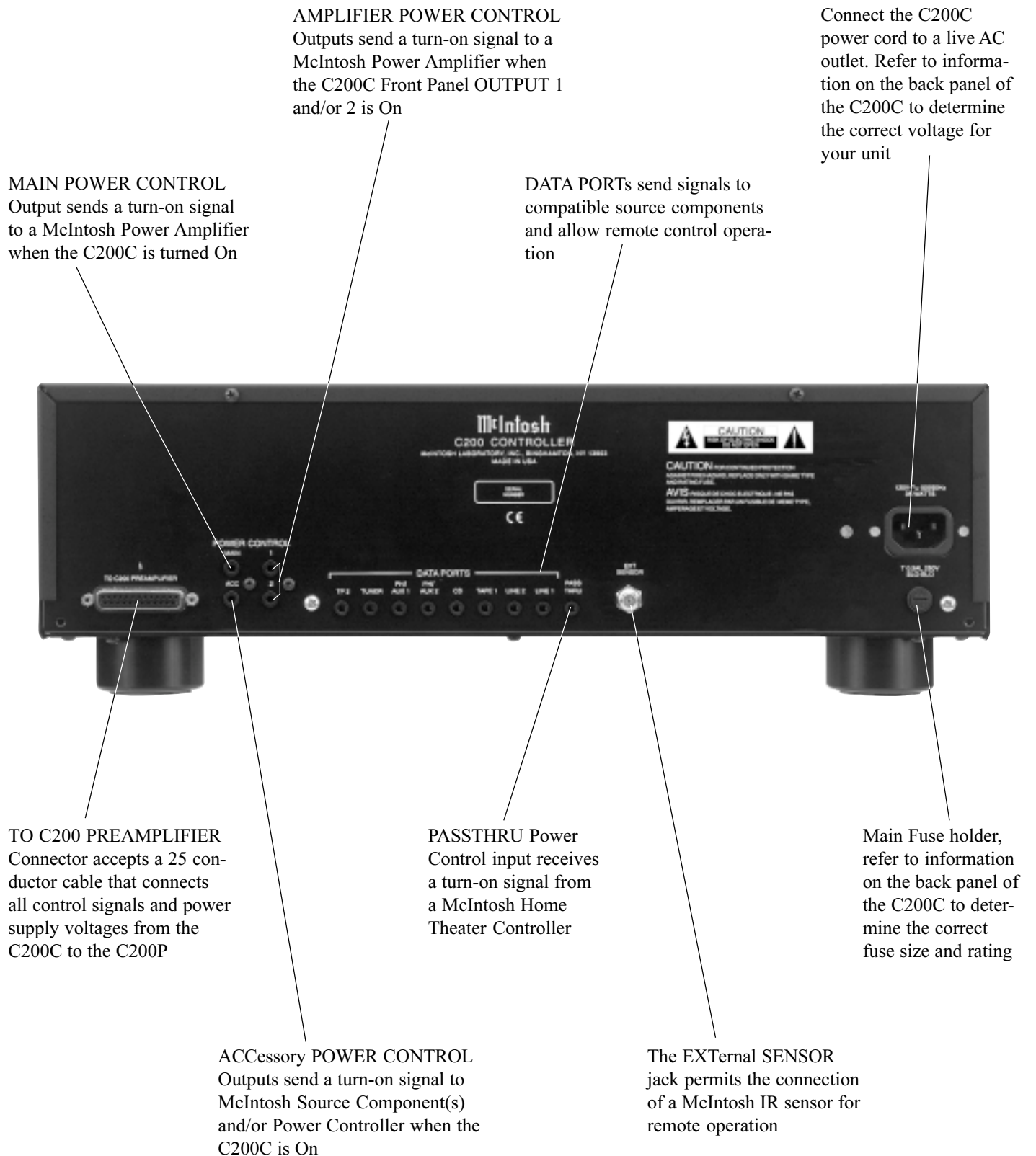

C200P Rear Panel Switches and Connections

MAIN Balanced
OUTPUTS contain
Listen program
signals at all times

SPKR/AMP 1 and 2
Balanced OUTPUTS
contain Listen signals
and turn On/Off with
the front panel OUT-
PUTS 1 and 2 push-
buttons

RECORD PROCESSOR
FROM and TO allows an
external signal processor to
be connected for use in the
Record mode

AUX 1 accepts high level program
source signals. PH 1 (MC) accepts low
level signals from a Moving Coil Phono
Cartridge and PH 1 (MM) accepts sig-
nals from a Moving Magnet Phono Car-
tridge. The small slide switch selects
which one of these three inputs is active
when either front panel LISTEN or
RECORD switch is set to PHX/AUX 1

TAPE 1 Balanced
OUTPUTS contain
Record Out Signals

LINE 1, LINE 2 and TAPE 1
Balanced INPUTS accept high
level program source signals

Ground connection
for turntables



TO C200C CONTROLLER
connector accepts a 25 con-
ductor cable that connects
all control signals and power
supply voltages from the
C200C to the C200P

TAPE 1, TAPE 2
unbalanced OUT-
PUTS contain
record out signals

AUX 2 accepts high level program
source signals. PH 2 (MM) accepts
signals from a Moving Magnet Phono
Cartridge. The small slide
selects which one of these inputs is ac-
tive when the front panel LISTEN or
RECORD Selector switch is set to PH/
AUX 2

LISTEN MAIN unbalanced
OUTPUTS contain Listen
program signals at all times

LISTEN PROCESSOR
FROM and TO allows an
external signal processor to
be connected for use in the
Listen mode

LISTEN unbalanced OUT-
PUTS 1 and 2 contain Listen
signals and turn on/off with the
front panel SPKR/AMP push-
buttons

TAPE 2, Tuner, and CD un-
balanced INPUTS accept high
level program source signals

How to Connect the C200

1. Connect the supplied DB25 cable from the C200C socket to the matching socket on the C200P.
2. Connect a Power Control Cable from the C200C POWER CONTROL MAIN Socket to the Power Control In Socket on one of the two McIntosh Power Amplifiers. Then connect from that Power Amplifier Power Control Out Socket to the second McIntosh Power Amplifier Power Control In Socket.

Note: There is approximately a one-half second delay in the turn-on of the second Power Amplifier, so as not to tax the AC Power Line.

3. Connect a Power Control Cable from the C200C POWER CONTROL ACCESSORY Socket to the Power Control In of a McIntosh Tuner.
4. Connect a Power Control Cable from the McIntosh Tuner Power Control Out Socket to the Power Control In of a McIntosh DVD Player and then onto the next McIntosh Source Component.
5. Connect a Data Cable from the C200C TUNER DATA PORT to the Data In of a McIntosh Tuner.
6. Connect a Data Cable from the C200C DVD DATA PORT to the Data In of a McIntosh DVD Player.
7. Connect an Audio Cable from the McIntosh Tuner Audio Outputs to the C200P TUNER INPUTS.
8. Connect an Audio Cable from the McIntosh DVD Player Audio Outputs to the C200P CD INPUTS.
9. Connect the remaining Audio Source and Processing Components to the matching C200P Inputs.

Note: It is important to make sure that the two C200P Rear Panel Slide Switches are set to the appropriate Input that a Source Component has been connected to. Example, if a second turntable is connected to the PH 2(mm) Input, then the Slide Switch must be set to the PH2 position and not AUX 2.

10. Connect XLR Cables from the C200P MAIN OUTPUTS (Balanced) to the Balanced Inputs on the two McIntosh Power Amplifiers.

Note: Balanced and Unbalanced Inputs and Outputs can be mixed. For example, you may connect signal sources to Unbalanced Inputs and send signals out from the Balanced Outputs. You can also use Balanced and Unbalanced outputs simultaneously, connected to different power amplifiers.

11. Connect the C200C power cord to a live AC outlet.

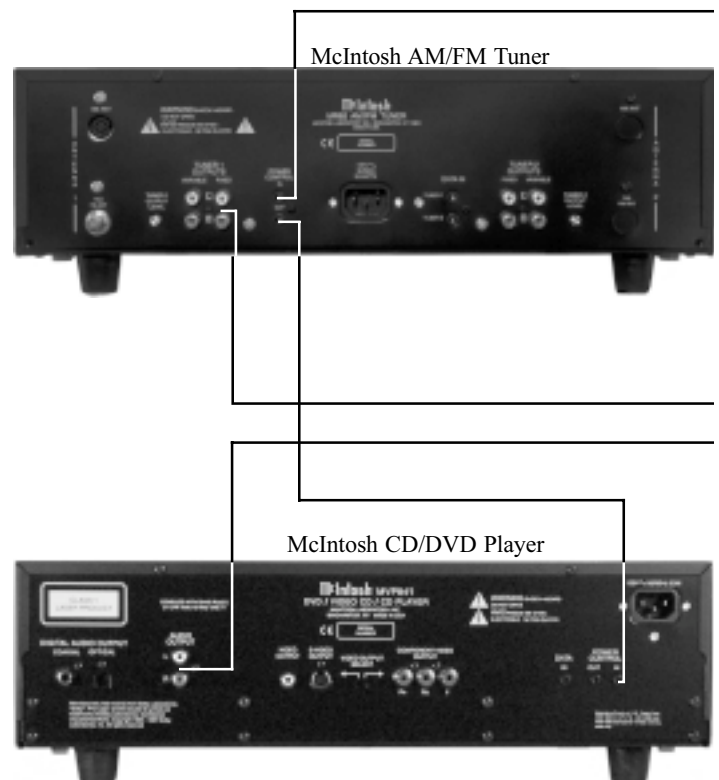

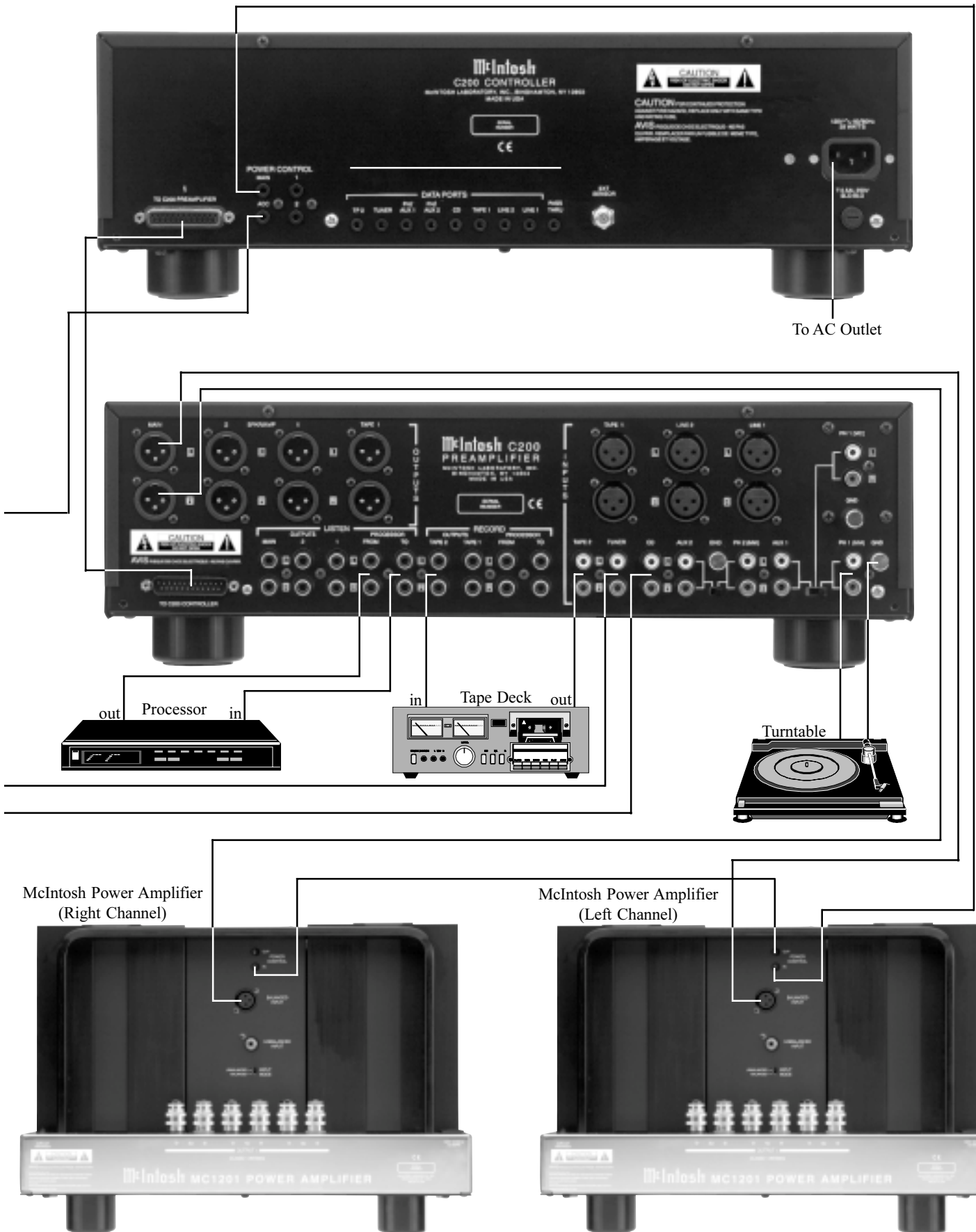

How to Connect the C200 with Passthru Mode

The Passthrough Mode on the C200 allows it to be part of a Multichannel System for the Left and Right Front Channels, when it is connected to a McIntosh Multichannel Processor such as the MX132, MSD4 or MAC-3.

1. Connect the supplied DB25 cable from the C200C socket to the matching socket on the C200P.
2. Connect a Power Control Cable from the C200C POWER CONTROL MAIN Socket to the Power Control In Socket on one of the two McIntosh Power Amplifiers. Then connect from that Power Amplifier Power Control Out Socket to the second McIntosh Power Amplifier Power Control In Socket.

Note: There is approximately a one-half second delay in the turn-on of the second Power Amplifier, so as not to tax the AC Power Line.

3. Connect a Power Control Cable from the C200C POWER CONTROL ACCessory Socket to the Power Control In of a McIntosh Tuner.
4. Connect a Power Control Cable from the McIntosh Tuner Power Control Out Socket to the Power Control In of a McIntosh DVD Player and then onto the next McIntosh Source Component.
5. Connect a Power Control Cable from the McIntosh A/V Controller Power Control Zone A to the C200C PASSTHRU Socket.
6. Connect a Data Cable from the C200C TUNER DATA PORT to the Data In of a McIntosh Tuner.
7. Connect a Data Cable from the C200C DVD DATA PORT to the Data In of a McIntosh DVD Player.
8. Connect an Audio Cable from the McIntosh A/V Controller Zone A Front Left and Right Audio Outputs to the C200P AUX 2 INPUTS.
9. Connect an Audio Cable from the McIntosh Tuner Audio Outputs to the C200P TUNER INPUTS.
10. Connect an Audio Cable from the McIntosh DVD Player Audio Outputs to the C200P CD INPUTS.
11. Connect the remaining Audio Source and Processing Components to the matching C200P Inputs.

Note: It is important to make sure that the two C200P Rear Panel Slide Switches are set to the appropriate Input that a Source Component has been connected to. Example, if a second turntable is connected to the PH 2(mm) Input, then the Slide Switch must be set to the PH2 position and not AUX 2, in order for the sound of the Turntable to be heard.

12. Connect XLR Cables from the C200P MAIN OUTPUTS (Balanced) to the Balanced Inputs on the two McIntosh Power Amplifiers.

Note: Balanced and Unbalanced Inputs and Outputs can

be mixed. For example, you may connect signal sources to Unbalanced Inputs and send signals out from the Balanced Outputs. You can also use Balanced and Unbalanced outputs simultaneously, connected to different power amplifiers.

13. Connect the C200C power cord to a live AC outlet.

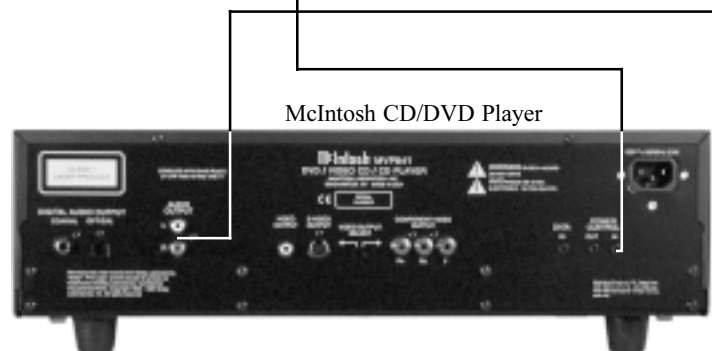
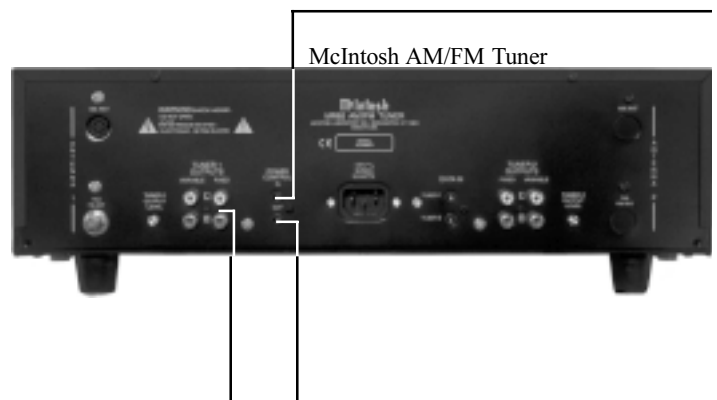
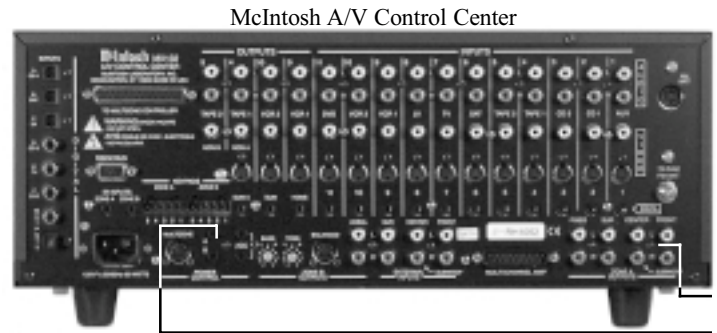

How to Connect the C200 with Passthru Mode

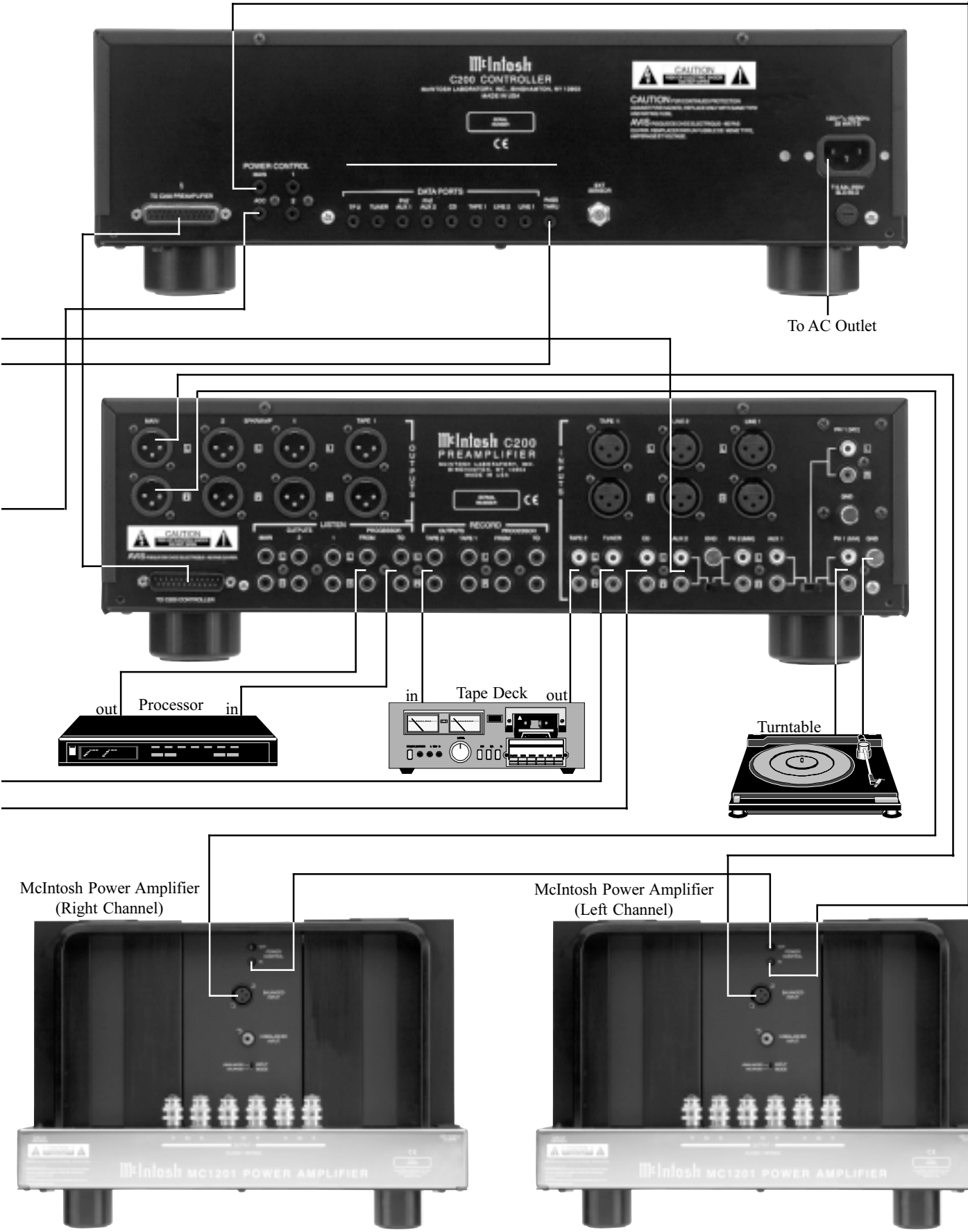

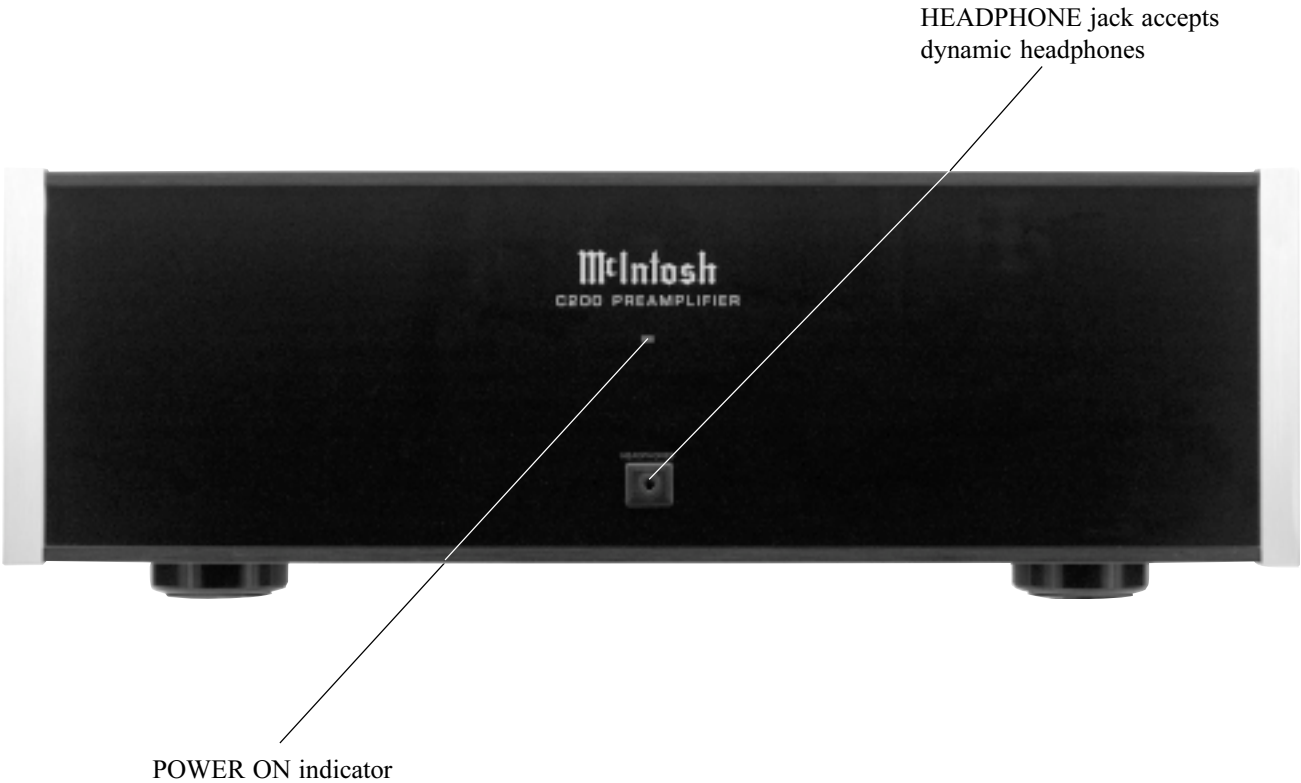

C200C Front Panel Controls, Displays, Push-Buttons, and Switches

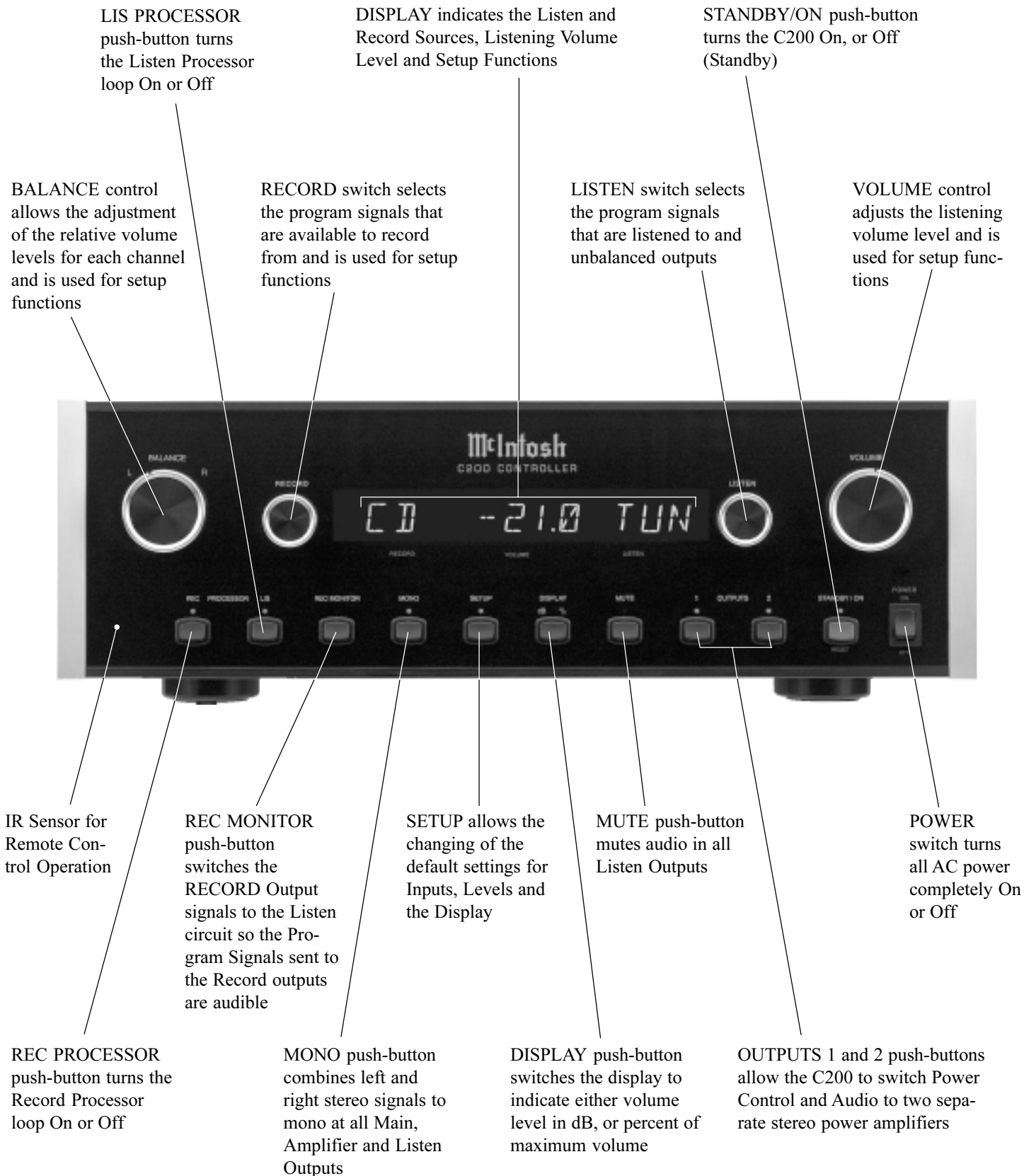

McIntosh

How to Operate the Setup Mode

Your McIntosh C200 has been factory configured for default operating settings that will allow you to immediately enjoy superb audio without the need for further adjustments. If you wish to make changes to the factory default settings (refer to the adjacent page), a Setup Feature is provided to customize the operating settings using the Front Panel Alphanumeric Display on the C200C Controller.

1. Press the POWER switch to ON, the Red LED above the STANDBY/ON push-button lights to indicate the C200 is in Standby mode. To turn on the C200 press the STANDBY/ON push-button. Refer to figure 1.



Figure 1

2. Press the C200 Front Panel SETUP push-button. The LED above the SETUP Push-button will illuminate and the Front Panel Display will indicate DISPLAY 20. Refer to figure 2.

Note: The Front Panel Display will indicate DISPLAY 20 the first time, after then it will display what ever Setup Mode was last accessed.



Figure 2

3. Rotate the BALANCE Control and notice that the Setup Mode advances through eight different possible adjustment selections and one informational display.
4. To exit from a specific Setup Mode press the SETUP Push-button a second time, the LED above the SETUP Push-button will extinguish and the Front Panel Display will revert back to its normal display. Refer to figures 3.



Figure 3

Default Settings

The following listings indicate the default settings and the page number for instructions on how to change a setting.

<u>Setup Function Name</u>	<u>Setting</u>	<u>Page Number</u>
Brightness (Display)	20	18
Text (Display Options)	Full	18
Trim (Input Level)	00	19
Input (On/Off)	On	19
Volume (Rate-of-Change)	VRV	20
Balance (Rate-of-Change)	VRB	20
Passthru (Multichannel)	Off	20
Remote (Control Type)	Norm	21
Version (C200 Firmware)	__ . __	21

Display Brightness

The Front Panel Alphanumeric DISPLAY Brightness may be varied from a setting of 1(Dim) to 31(Bright), follow the steps below for changing the brightness. Refer to figure 4.



Figure 4

1. Press the SETUP Push-button to access the Setup Mode.
2. Rotate the BALANCE Control Knob until the word DISPLAY 20 appears.
3. Rotate the LISTEN Switch Knob until the desired Display Brightness is achieved.
4. Press the SETUP Push-button to exit the Setup Mode.

Text Display Options

There are two choices for the displaying of Input Names on Front Panel Alphanumeric Display, TEXT FULL or TEXT SHORT. The TEXT FULL Mode displays the Volume Setting together with the name of the Listen Input Selected. Refer to figure 5. The TEXT SHORT Mode displays the name of Record Input Selected, the Volume Setting and the name of the Listen Input Selected. Refer to figure 6.



Figure 5

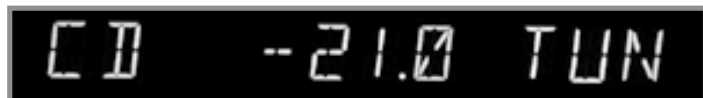

Figure 6

1. Press the SETUP Push-button to access the Setup Mode.
2. Rotate the BALANCE Control Knob until the words TEXT FULL appears. Refer to figure 7.
3. Rotate the LISTEN Switch Knob until the display indicates TEXT SHORT. Refer to figure 8.
4. Press the SETUP Push-button to exit the Setup Mode.



Figure 7



Figure 8

Input Trim Level

Various components can have slightly different volume levels. This could result in the constant need to readjust the C200 volume control when switching between different Listen Program Sources. A volume trim feature on the C200 allows you to adjust or trim the levels of the various inputs so that they have the same relative volume. The Phono1 Input is used in the example below.

Note: The possible range of adjustment in volume level is ± 12 dB. The Record Output Levels are unaffected by any changes in the Trim Settings. Any TRIM adjustments made are retained in permanent memory and can be changed only by performing a new TRIM procedure.

1. Rotate the LISTEN Switch Knob to select the Phono1 Input and adjust the VOLUME Control to the desired listening level.
2. Press the SETUP Push-button to access the Setup Mode.
3. The Front Panel Alphanumeric Display will change and the Red LED above the SETUP Push-button will turn On.
4. Rotate the BALANCE Control Knob until the words TRIM 00 PH1 appears. Refer to figure 9.



Figure 9

5. Rotate the VOLUME Control until the desired volume level is achieved. Refer to figures 10 and 11. Figure 10 indicates a +3dB increase in the PH1 Level and figure 11 has a -5dB decrease in level.

Note: Choose a Input Source that is frequently listened to as the reference. The reference Input Source should be set to a Trim Level of 00.



Figure 10

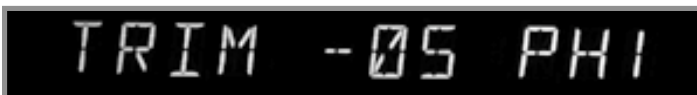

Figure 11

6. Rotate the LISTEN Switch Knob until the next desired Input Source Name is displayed.
7. Repeat steps 3 and 4 until all the Inputs with sources connected to the C200 have the same relative volume levels when switching between them.
8. Press the SETUP Push-button to exit the Setup Mode.

Note: Whenever a program source selected has trimmed volume levels, the Front Panel Display Volume

Indication will automatically move up or down when changing between Input Sources to reflect the differences in trim levels. The Trim Level can also be set via the remote control. The following table may be used to record your level trim adjustments for the various inputs.

Input Source	Default Setting	New Setting
Tuner	0	
Tape 1	0	
Tape 2	0	
Line 1	0	
Line 2	0	
Phono 1 / Aux 1	0	
Phono 2 / Aux 2	0	

Input Selection

The C200 allows the turning off of unused Input Sources. This prevents having to go through all the eight positions on the LISTEN and RECORD Switches when there may only be four Input Sources Connected to the C200. The Phono 1 Input is used in the example below.

Note: If all the Input Sources have been turned Off and the C200 is no longer in the Setup Mode, the Front Panel Display will Indicate NO SOURCE. Two Input Positions on the C200 have a Rear Panel Slide Switch associated with them. This allows selection of three additional component sources to be connected, however only eight possible Input Sources can be selected from at any one time.

1. Rotate the LISTEN Switch Knob to select the Phono1 Tuner Input.
2. Press the SETUP Push-button to access the Setup Mode.
3. Rotate the BALANCE Control Knob until the words INPUT ON PH1 appears. Refer to figure 12.



Figure 12

4. Rotate the LISTEN Switch Knob until the desired Input Source Name that you want to turn Off is displayed.

5. Rotate the RECORD Switch Knob one position. The display should indicate INPUT -- PH1. Refer to figure 13.



Figure 13

6. Press the SETUP Push-button to exit the Setup Mode.

The Phono1 Input is now switched Off. To switch the Phono1 Input back On, repeat steps 1 through 6 except reverse the settings for steps 4 and 5. To switch Off any other non-used Inputs, follow steps 1 through 6.

Volume Control Rate-of-Change

The C200 offers three choices for the rate-of-change in volume levels as the Volume Control Knob is rotated. The VOLUME SLOW Setting permits the smallest changes in volume per degree of rotation, as the Volume Control Knob is rotated. The VOLUME FAST Setting permits larger changes in volume per degree of rotation, as the Volume Control Knob is rotated. The VOLUME VRV (Variable Rate Volume), which is the default setting, combines the best of the Volume Fast and Slow Settings, plus adds an additional Super Fast rate-of-change at the very beginning of rotation. At the start of the Volume Control Rotation, the changes in volume per degree of rotation are very rapid and then the changes in volume become smaller as the rotation of the Volume Control continues.

1. Press the SETUP Push-button to access the Setup Mode.
2. Rotate the BALANCE Control Knob until the words VOLUME VRV appears. Refer to figure 13.



Figure 13

3. Rotate the LISTEN Switch Knob and select either VOLUME SLOW or VOLUME FAST setting. Refer to figures 14 and 15.



Figure 14



Figure 15

4. Press the SETUP Push-button to exit the Setup Mode.

Balance Control Rate-of-Change

There are two choices for the rate-of-change in the Left and Right Channel Volume Levels as the Balance Control Knob is rotated. The BALANCE SLOW Setting permits the smallest changes in channel balance, with the changes being proportional to the speed of rotation, as the Balance Control Knob is turned. The BALANCE VRB (Variable Rate Balance), which is the default setting, the changes in channel volume level are accelerated as the speed of the Balance Control Knob is increased.

1. Press the SETUP Push-button to access the Setup Mode.
2. Rotate the BALANCE Control Knob until the words BALANCE VRB appears. Refer to figure 16.



Figure 16

3. Rotate the LISTEN Switch Knob and select the BALANCE SLOW setting. Refer to figure 17.



Figure 17

4. Press the SETUP Push-button to exit the Setup Mode.

Passthru Mode

The C200 can be part of a Multichannel Sound System for DVD-Audio and Home Theater. The Right and Left Front Channels from a McIntosh A/V Control Center or Surround Decoder can “Passthru” the C200 and onto its associated Power Amplifier(s). The Setup Mode allows the activation of the Passthru Mode and the Selection of the C200 Input that will be used for the Right and Left Front Channels. In the example below, the Right and Left Front Channels from the Multichannel Processor/Decoder will be connected to the AUX 2 Input Sockets on the C200.

1. Press the SETUP Push-button to access the Setup Mode.
2. Rotate the BALANCE Control Knob until the words PASSTHRU OFF appears. Refer to figure 18.



Figure 18

3. Rotate the LISTEN Switch Knob until AU2 is displayed. Refer to figure 19.



Figure 19

4. Press the SETUP Push-button to exit the Setup Mode.

Remote Control Selection

There are two choices for the Remote Control Codes that the C200 will respond to. The Remote Control that came with the C200 utilizes the NORMal McIntosh Control Codes. The Second Set of Control Codes that the C200 will respond to is referred to as the ALTErnate Codes.

Note: If the ALT Remote Control Code is selected, the C200 will not respond using the supplied McIntosh Remote Control.

1. Press the SETUP Push-button to access the Setup Mode.
2. Rotate the BALANCE Control Knob until the words REMOTE NORM appears. Refer to figure 20.



Figure 20

3. Rotate the LISTEN Switch Knob and select the REMOTE ALT setting. Refer to figure 21.



Figure 21

4. Press the SETUP Push-button to exit the Setup Mode.

Firmware Version

The C200 functionality is controlled by internal software that is known as Firmware. The Version of the Firmware in the C200 can be identified at any time by utilizing the Setup Mode.

1. Press the SETUP Push-button to access the Setup Mode.
2. Rotate the BALANCE Control Knob until the word VERSION _ . _ _ appears. Refer to figure 22.



Figure 22

3. The number after the word VERSION is the Firmware number.
4. Press the SETUP Push-button to exit the Setup Mode.

How to Operate the C200

Power On

Press the POWER switch to ON. The Red LED above STANDBY/ON Push-button lights to indicate the C200 is in Standby mode. To turn-on the C200 press the STANDBY/ON Push-button. Refer to figure 23.

Note: The POWER Switch is only intended to be switched Off when the C200 Controller/Preamplifier is not used for extended periods of time, like while away on vacation. During normal operation, the POWER Switch should stay in the On Position. Press the STANDBY/ON Push-button for turning the C200 On and Off. The C200 may also be turned On or Off with the supplied Remote Control.



Figure23

Balance Control

Adjust the BALANCE control as needed to achieve approximately equal listening volume levels in each loudspeaker. Turn the BALANCE to the Left to emphasize the left channel by reducing the level of the right channel. Turn the BALANCE to the right to emphasize the right channel by reducing the level of the left channel.

Balance Display

As soon as the BALANCE control is turned, the Volume Display reads the balance change from 1 to 107 in one dB steps. After approximately 3 seconds the Volume Display returns to the Volume reading. To verify the balance setting without changing it, move the control one detent in either direction. The display will indicate the selected balance changes for approximately 3 seconds and then return to the volume display.

The "L" or "R" will illuminate red to indicate which channel has been emphasized by the BALANCE control. It

is perfectly natural for the BALANCE control to be off the center to achieve the correct listening volume from each loudspeaker in many listening rooms. Listening balance can also vary with different program sources, room acoustics and listening positions relative to the loudspeakers.

Source Selection

Select the desired Listening Source with the LISTEN Switch and the Tape Output Source with the RECORD Switch.

Volume Control

Adjust the VOLUME control for the desired listening level.

Volume Display

Press the DISPLAY push-button to select either dB or % volume indication on the Front Panel Alphanumeric Display. The dB readings range from -92dB to +15dB, in 0.5dB steps. The % volume display reads from 0 to 100.

Processors

Press the LIS PROCESSOR Push-button to place an external Sound Processor into the Listen Signal Path for all inputs. In a similar manner, press the REC PROCESSOR Push-button to place an external Record Sound Processor into Tape Out Signal Path for both Tape 1 & 2 Outputs.

Record Monitor

Press the REC MONITOR Push-button to hear the Signal Source that is available at the Tape Out Jacks for recording.

Note: If the Text Full Mode has been selected, the Front Panel Alphanumeric Display will display the Text Short Mode in order to indicate Selected Record Source.



Figure 24

Mono

Press the MONO push-button to combine left and right stereo signals to mono at the LISTEN MAIN, LISTEN OUTPUTs 1&2 , OUTPUTS (Balanced) MAIN, SPKR/AMP 1&2 and HEADPHONES Outputs.

Setup

Pressing the SETUP Push-button activates the Setup Mode of the C200 and allows customizing the Front Panel Alphanumeric Display, Input Selection and Trim Levels, Volume and Balance Controls Rate-of-Change, Passthru Mode, Remote Control Type and Firmware Version.

Mute

Press the MUTE push-button to mute audio in all Listen Outputs and the Front Panel Alphanumeric Display will indicate MUTE in place of the actual volume setting. Refer to figure 25.



Figure 25

Output 1 and 2

Press OUTPUT 1 or 2 Push-buttons to send audio to separate power amplifiers connected to the rear panel OUTPUTS 1 or 2. It also activates the POWER CONTROL 1 &2 Sockets on the rear panel of the C200C. You can press either push-button individually or both together.

Reset of Microprocessors

In the event that the controls of the C200 stop functioning, switch the POWER Switch to the Off Position and wait for about three minutes. Press the POWER Switch to the ON position and press the STANDBY/ON Push-button. This will reset the C200 microprocessors.

Note: The above condition is usually caused by either interruptions in AC power and/or major changes in voltage.

How To Make A Tape Recording

The separate RECORD and LISTEN switches allow you to make a tape recording from one program source while listening to another. You can also listen (monitor) to the recorded signal off the tape, a fraction of a second later, during recording when a three head tape recorder is used. You can also listen to the signal being fed to the tape recorder by pressing the REC MONITOR push-button. Refer to figure 24.

1. Select the desired program source to record with the front panel RECORD selector switch.
2. Adjust the record level using the tape recorder volume control.
3. To listen to the signal being fed to the tape recorder, press the REC (Record) MONITOR push-button.
4. To listen to the tape playback of the program source just recorded, turn the LISTEN switch to the desired input.

Note: The C200 RECORD OUTPUTS are not affected by the VOLUME or BALANCE controls. To listen to a different program source while recording, turn the LISTEN switch to the desired source. The recording process will not be affected and will continue.

How to use a Signal Processor

Access and operate a signal processor connected to the LISTEN PROCESSOR jacks by pressing the front panel LIS (Listen) PROCESSOR push-button. This processor will affect only the LISTEN signals. Refer to figure 24.

Access and operate a signal processor connected to the RECORD PROCESSOR jacks by pressing the front panel REC (Record) processor push-button. This processor will affect only the RECORD signals sent to tape recorders. Refer to figure 24.

How to use the Passthru Mode

When the C200 is connected together with a McIntosh Multichannel A/V Control Center or Surround Decoder and has the PASSTHRU MODE activated it will automatically turn-on when ever the A/V Control Center or Surround Decoder is turned on. It will indicate on the Front Panel Alphanumeric Display "PASSTHRU". Refer to figure 26.



Figure 26

In the Passthru Mode, the LISTEN and RECORD Processor and OUTPUTS 1&2 Push-buttons remain active. The remaining C200C Front Panel Controls and Push-buttons are deactivated as long as the C200 is in the Passthru Mode. The C200 will also remember the settings of the LISTEN and RECORD Processor and OUTPUTS 1&2 Push-buttons for the Passthru Mode; it stores these settings separately, from the settings when only the C200 is On.

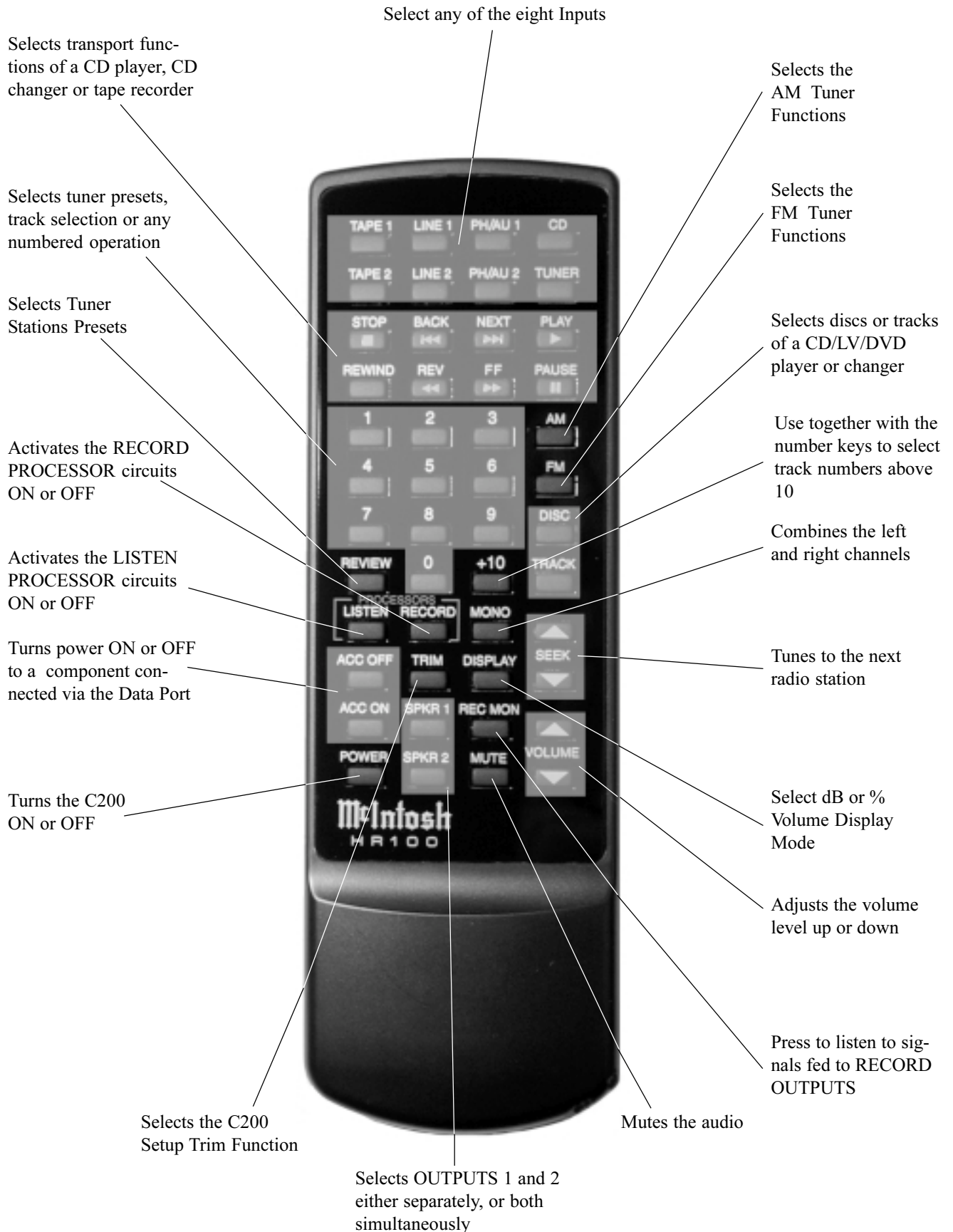

Mute

Press the MUTE push-button to mute audio in all LISTEN outputs.

Mono

Press the MONO push-button to combine left and right stereo signals to mono at all MAIN, AMPLIFIER, LISTEN and HEADPHONES Outputs.

Input Selection

Press any of the eight Input push-buttons to select a LISTEN program source.

Transport Functions

Use the Transport Function Push-buttons to operate a CD player, CD changer or tape recorder.

Note: Non-McIntosh CD, DVD and Tape Recorder Components may be controlled with the C200 Remote Control when they are connected together with a McIntosh RCT Translator. Refer to the RCT Owner's Manual for further information on alternate Remote Control push-button functions.

Numbered and +10 Push-buttons

Press push-buttons 0 through 9 to access tuner station presets, CD tracks or CD discs. When using a McIntosh CD player, access track numbers higher than 10 by first pressing +10 and then a number push-button.

Disc and Track

Use the DISC and TRACK push-buttons when a CD player or changer is being used.

Tuner Functions

Select AM or FM broadcast band. Press and release SEEK Up or Down to move from station to station. Press and hold a SEEK push-button to move continuously from station to station. Press REVIEW to start the automatic brief audition of each of the presets stored in the tuner memory. Press REVIEW a second time to stop on a station preset and exit the Review process.

Note: Non-McIntosh Tuners may be controlled with the C200 Remote Control when they are connected together with a McIntosh RCT Translator. Refer to the RCT Owner's Manual for further information on alternate Remote Control push-button functions.

Processors

Press the LISTEN PROCESSOR push-button to activate rear panel processor connections to add signal processing from an external processor to the LISTEN Outputs. Press the RECORD PROCESSOR push-button to activate rear

panel connections to add signal processing from an external processor to the RECORD outputs.

Record Monitor

Press the REC (Record) MONitor push-button to listen to the signals being fed to the RECORD OUTPUTS.

Volume

Press the Up or Down VOLUME push-button to raise or lower the listening volume level. The Record Outputs are not affected.

Trim

Press the TRIM push-button to enter the C200 Setup Trim Mode. Press a second time to exit the Setup Trim Mode.

Note: Refer to the Setup Section contained elsewhere in this Owner's Manual.

Display

Press the DISPLAY push-button to cycle the Volume Display between dB and % of volume indications.

Accessory Power Control

Press ACCESSORY ON or ACCESSORY OFF to turn Power On and Off with some McIntosh Source Components and non-McIntosh Source Components that are connected with a McIntosh RCT Translator.

Note: Only the ACC ON push-button is active with the McIntosh LV or DVD Disc Player.

Optional Remote Control

If the C200 is used in the Passthru Mode, an optional McIntosh Remote Control Model UR12 allows an Alternate Set of Remote Control Codes for the C200 to be used. This will prevent the C200 from responding to the Remote Control that comes with the McIntosh A/V Control Center or Surround Decoder. See your McIntosh Dealer for additional information. Refer to figure 27.



Figure 27

Specifications

Frequency Response

+0, -0.5dB from 10Hz to 40,000Hz

Total Harmonic Distortion

0.002% from 20Hz to 20,000Hz

Signal To Noise Ratio

Phono, 86dB

High Level, 100dB

Maximum Voltage Output

12V RMS Unbalanced, 25V RMS Balanced

Output Impedance

50 ohms, Balanced and Unbalanced

Sensitivity

Phono MM, 4.4mV for 2.5V rated output (1mV IHF)

Phono MC, 140uV for 2.5V rated output

High Level, 450mV for 2.5V rated output

Input Impedance

Phono MC, 10 ohms

Phono MM, 47K ohms, 65pF

High Level, 22K Unbalanced, 44K Balanced

Maximum Input Signal

Phono MM, 50mV

High Level, 5V Unbalanced, 5V Balanced

Power Requirements

100 Volts, 50/60Hz at 30 watts

110 Volts, 50/60Hz at 30 watts

120 Volts, 50/60Hz at 30 watts

220 Volts, 50/60Hz at 30 watts

230 Volts, 50/60Hz at 30 watts

240 Volts, 50/60Hz at 30 watts

Overall Dimensions

17-1/2 inches (44.5cm) W, 6 inches (13.7cm) H, 20 inches (44.5cm) D (including clearance for connectors)

Weight

C200C - 26.0 pounds (11.79 kg) net, 40.4 pounds (18.32 kg) in shipping carton

C200P - 20.5pounds (9.3 kg) net, 34.9 pounds (15.82 kg) in shipping carton

Note: Refer to the rear panel of the C200C for the correct voltage.

Packing Instructions

In the event it is necessary to repack the equipment for shipment, the equipment must be packed exactly as shown below. It is very important that the four plastic feet are attached to the bottom of the equipment. This will ensure the proper equipment location on the bottom pad. Failure to do this will result in shipping damage.

Use the original shipping carton and interior parts only if they are all in good serviceable condition. If a shipping carton or any of the interior part(s) are needed, please call or write Customer Service Department of McIntosh Laboratory. Please see the Part List for the correct part numbers.

Quantity	Part Number	Description
1	033838	Shipping carton only
4	033837	Foam End Caps
1	033836	Inside carton only
1	033725	Foam Pad
1	034149	Bottom pad
4	018578	Plastic foot
4	100159	#10-32 x 3/4" Machine screws
4	104083	#10-7/16" Flat washers

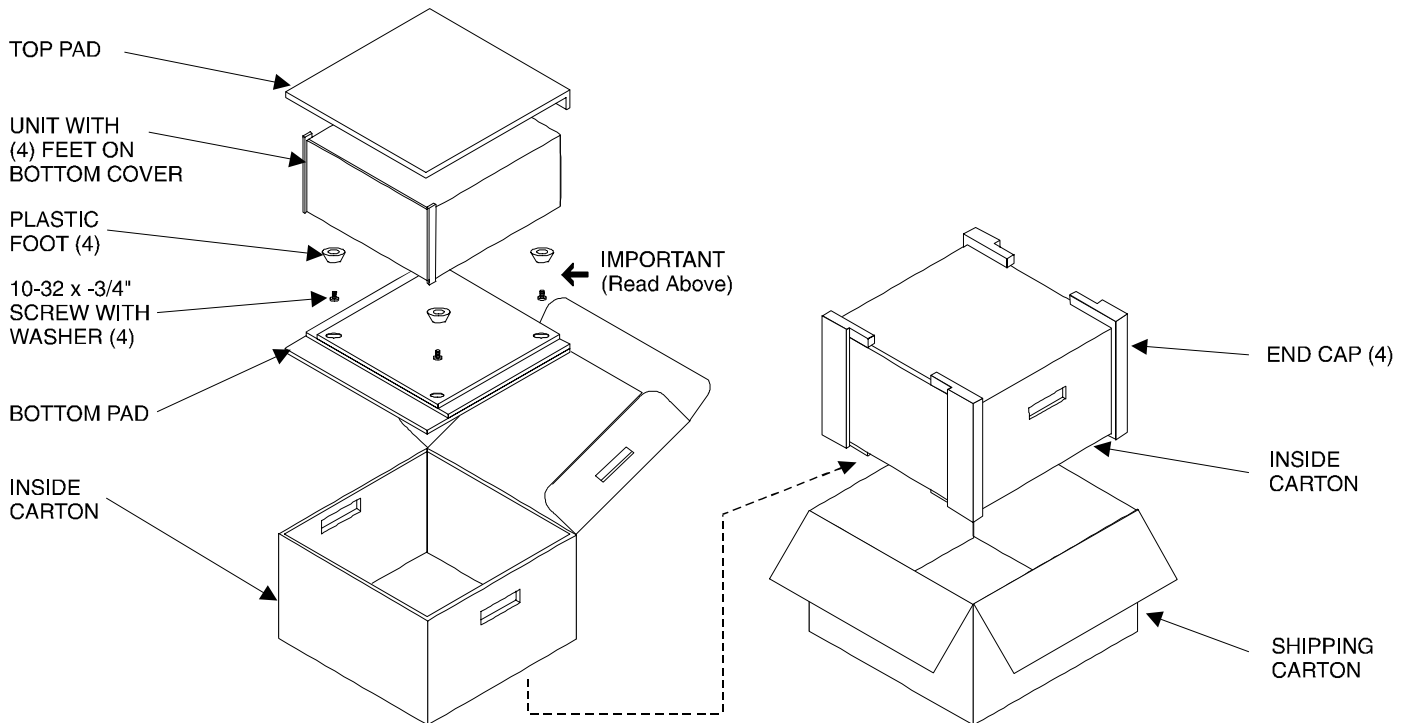

McIntosh[®]

McIntosh Laboratory, Inc.
2 Chambers Street
Binghamton, NY 13903